



**TOYOTA**

LEAD THE WAY



***LAND CRUISER 70 SERIES***

# LAND CRUISER 70 SERIES



## CONTENTS

01 |  | INTRODUCTION: LAND CRUISER 70 SERIES

03 |  | THE LAND CRUISER 76 V8 STATION WAGON

05 |  | THE LAND CRUISER 79 SINGLE CAB

07 |  | THE LAND CRUISER 79 DOUBLE CAB

11 |  | ENGINE AND PERFORMANCE

13 |  | ACCESSORIES

14 |  | THE LAND CRUISER SPEC SHEET

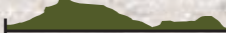
16 |  | TOYOTACARE



70 Series

# AS RUGGED AS AFRICA



The indestructible Land Cruiser 70 series surrenders to no challenge; it is steadfast and bold. This range of vehicles is built to perform and work as hard as you do, which is why they have been at the helm of 4x4 African motoring for more than 60 years. A 4.5 litre V8 engine with 151 kW of power and 430 Nm of torque is now available in the Station Wagon, Single Cab and Double Cab ranges. Tackling the toughest of terrains with ease, the Land Cruiser 70 series is truly as rugged as Africa.

The Land Cruiser 70 series is available in seven models:  
Land Cruiser 76 Station Wagon Diesel 4.5ℓ V8  
Land Cruiser 79 Single Cab Diesel 4.2ℓ  
Land Cruiser 79 Single Cab Petrol 4.0ℓ

Land Cruiser 79 Single Cab Diesel 4.5ℓ V8  
Land Cruiser 79 Double Cab Diesel 4.2ℓ  
Land Cruiser 79 Double Cab Petrol 4.0ℓ  
Land Cruiser 79 Double Cab Diesel 4.5ℓ V8



Model shown: Land Cruiser 79 Double Cab

70 Series **76 V8 STATION WAGON**

# EMBARK ON AN AFRICAN ADVENTURE

If you're planning on venturing into the wild open country, the Land Cruiser 76 V8 Station Wagon is the perfect vehicle to see it all and get away from it all. Its spacious interior can seat up to five adults in comfort with extra space for luggage. The vehicle also has a fuel capacity of 130 litres to take you further into the wilderness.

The Land Cruiser 76 V8 Station Wagon has the flexibility of a five-seater with the formidable ability of a 4x4, making it the perfect vehicle to witness the wonder of nature with the whole family. The 4.5 litre V8 engine with 151 kW of power and 430 Nm of torque will turn any mountain into a mere molehill.

## The Interior

Even though the Land Cruiser 76 V8 Station Wagon is about roughing it in the great outdoors, its interior is comfort-centred. A rear console helps keep everything in its place, plus the back pockets on the driver and front passenger seats give the rear passengers space to store whatever they need for the journey ahead. A rear bench adds extra seating space for up to five passengers, while the station wagon's impressive proportions allow ample legroom for all its occupants. For convenience, the Land Cruiser 76 V8 has electrically adjustable windows.

## The Exterior

The Land Cruiser 76 V8 is much more than a station wagon! Everything about it is rugged, from its imposing 230 mm ground clearance down to the 16" alloy wheels. Its already strong-featured look is taken to the next level with the painted and plated front bumper, while the aluminium side steps make getting in and out of the Land Cruiser 76 V8 simple.



**SUTHERLAND.**

**TO SEE THE BRIGHTEST STARS  
IN THE WORLD YOU NEED TO  
GO TO THE COLDEST PLACE IN  
SOUTH AFRICA, A PLACE  
WHERE TEMPERATURES  
FALL TO  $-16.4^{\circ}\text{C}$ .  
TAKE THE ANCIENT ROAD  
TO SUTHERLAND. ABOVE  
YOU, YOU'LL FIND THE  
MAP OF THE UNIVERSE AS  
A BELT OF BRILLIANCE.  
BELOW YOUR LAND CRUISER,  
THE ROCKS OF MILLENNIA PAST.**

70 Series **79 SINGLE CAB**

# BRAVELY COMBAT THE TERRAIN

This vehicle is the ultimate workhorse for the tough African environment. It has got the power to take charge of the most demanding conditions and even with a full one-ton load, this pick-up will go wherever you take it. It is also available in a 4.5 litre V8 engine with 151 kW of power and 430 Nm of torque that will give your Land Cruiser extra staying power to go where most wouldn't dare.

## THE EXTERIOR

The Land Cruiser 79 Single Cab is reliable through and through. Its all-welded integral cabin provides extra strength and safety, which reduces dust/water entry and corrosion that could result from deep water driving. The heavy-duty frame, suspension and drivetrain ensure it can carry the heaviest of loads, both on and off-road. This is aided by the super long wheelbase of 3180 mm. Front fog lamps, alloy wheels and chrome finishes on the grille and door handles make the Land Cruiser 79 Single Cab not only practical but adds an edgy style to it as well.

## THE INTERIOR

The interior of the Land Cruiser 79 is not only practical, it's built to be comfortable for the driver and passenger no matter where their work takes them. An air conditioner to ensure you're never at the mercy of the weather, regardless of the temperature outside, is a standard feature. Front bottle holders to keep your drinks spill-free, and the lockable glove box to safely stow-away your possessions are two other standard features. For convenience, the Land Cruiser 79 Single Cab also has electrically adjustable windows.



**SWARTBERG PASS.**

**A LIFELINE BETWEEN THE TOWNS  
OF THE GROOT KAROO AND  
KLEIN KAROO.**

**THE UNTARRED ROAD LEADS  
TO THE SUMMIT 1 583 METRES  
ABOVE SEA LEVEL IN STEEP  
ZIGZAGS AND  
SUDDEN SWITCHBACKS.**

**IT'S DANGEROUS, YES.  
BUT EVERY BIT WORTH THE THRILL.  
IN THE LAND CRUISER YOU'LL FIND  
NO DANGER, JUST ADVENTURE AWAITS.**

Model shown: Land Cruiser 79 Single Cab Diesel 4.5l V8

70 Series **79 DOUBLE CAB**

# DO ANYTHING, EXPLORE EVERYWHERE

The Land Cruiser 79 Double Cab comes equipped with the durability of the Land Cruiser 79 Single Cab and the extra advantage of rear seating space in the cabin. The Double Cab is multi-functional – it's strong enough to carry heavy loads and is versatile enough to transport five occupants in comfort. The Double Cab is also available in a 4.5 litre V8 engine with 151 Kw of power and 430 Nm of torque, so you can get anyone or anything - anywhere.



Model shown: Land Cruiser 79 Double Cab

## THE EXTERIOR

Taming the African wild is no mean feat. A certain resilience is needed, something the Land Cruiser 79 Double Cab has got in bakkie loads. This vehicle delivers a go-anywhere carrying capacity in style. The Land Cruiser 79 comes standard with chrome finishes on the grille and door handles, aluminium side steps, as well as front fog lamps. The load bay is 1525 mm in length and 1600 mm wide with a load capacity of between 920 kg and 1005 kg, depending on which model you choose.



Tilt adjustable steering wheel



Centre console of the Land Cruiser 79 Double Cab

Dash shown: Land Cruiser 79 Double Cab

Available vehicle may differ from vehicle shown

## THE INTERIOR

The Land Cruiser 79 Double Cab's exterior is made to be indestructible but its interior features afford you and your passengers the highest level of comfort. Electrically adjustable windows and an air conditioner to make even the hottest of places bearable, while an audio system with Bluetooth and USB port makes sure you're never bored on desolate stretches of road.

Driver and front passenger seat back pockets

## THE NAMIB DESERT.

THE NAMIB DESERT IS AN ECO-SYSTEM OF CONTRASTS. IT'S A PLACE WHERE COASTLINE MEETS WITH DESERT, A PLACE WHERE THE HARDIEST OF CREATURES SURVIVE. TEMPERATURES SOAR TO 40°C AND THE HEAT PERMEATES EVERY CONCEIVABLE LIVING SPACE. NIGHTTIME APPROACHES, TEMPERATURES QUICKLY FALL TO BELOW 0°C. NAMIBIA IS A PLACE OF HIGH HIGHS AND LOW LOWS, A PLACE THE LAND CRUISER CAN TACKLE WITH EASE.



# POWER OVER THE WILDERNESS

The Land Cruiser 70 range is suited for any call up; its three powerful and reliable engine options conquer the toughest of terrains. The 4.2 litre diesel engine delivers power of 94 kW @ 3800 and 280 Nm @ 2200 r/min on the Land Cruiser 79 Single Cab and 79 Double Cab. The 4.0 litre petrol engine available only on the Land Cruiser 79 Single Cab and Double Cab delivers power of 170 kW @ 5200 r/min and torque of 360 Nm @ 3800 r/min. The Land Cruiser Station Wagon, Single Cab or Double Cab are available with a 4.5 litre V8 engine with 151 Kw of power and 430 Nm of torque, running on a 5-speed manual transmission to conquer even the most seemingly impossible challenges.

The Land Cruiser 70 range features a 5-speed manual transmission and an additional 4-position 4-wheel drive transfer lever, giving the driver maximum control. Its coil spring rigid axle front suspension, in combination with its long wheelbase, offers outstanding directional stability at any speed, in any condition. A leaf spring rigid axle rear suspension ensures that occupants are always comfortable. The Land Cruiser 76 V8 has a ground clearance of 230 mm, while the Land Cruiser 79 model is 235 mm above the ground, allowing the vehicles to handle off-road conditions with confidence.

## PROTECTION FROM THE ELEMENTS (and anything else Africa throws at you)

It takes ultimate courage to stand up to the challenges that make Africa uniquely African. The Land Cruiser 70 range is confidently geared to withstand whatever perilous conditions it encounters; its safety and security standards are class-leading.

Driver and front passenger airbags are standard on all models, and the extended front bumper prevents unnecessary airbag response when driving off-road. The Land Cruiser 70 range comes with an additional safety feature, the Anti-lock Braking System (ABS) which prevents wheels from locking up when driving on slippery surfaces. Rear differential on all models give extra traction to the rear-wheels to help you negotiate your way out of difficult situations. Ventilated front disc brakes and rear drum brakes make stopping easier on any terrain. For security and peace of mind, all the vehicles in the Land Cruiser 70 V8 models are fitted with an immobiliser, wireless door lock on the entire range.

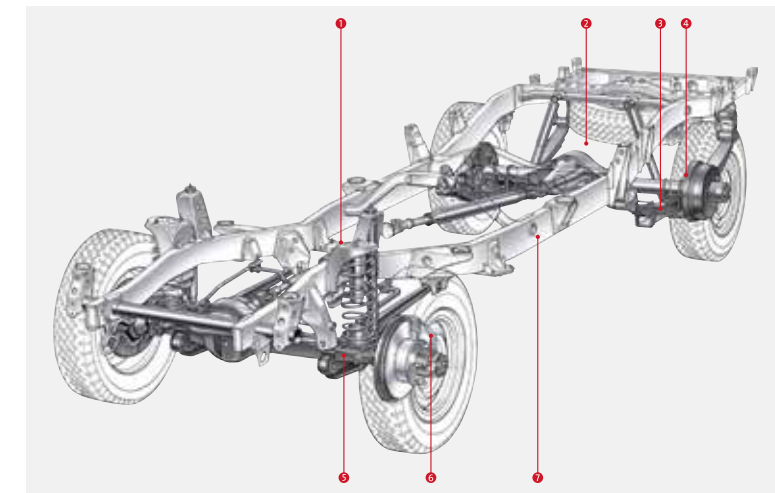

- 1 Coil spring front suspension for good road holding and ride comfort
- 2 Heavy duty, durable differential pinions (Single Cab)
- 3 Long rear leaf springs
- 4 Strong and durable drive shafts
- 5 Durable solid front axle
- 6 Ventilated front disc brakes
- 7 Extra-strong heavy duty ladder frame



# BECAUSE EVERY AFRICAN CHALLENGE IS DIFFERENT...

The Land Cruiser 70 series range is made to work for you and with you, whatever job you might have. Choose from our long list of accessories that best suit your Land Cruiser:

## ACCESSORIES

Product/item	LC79 SC		LC79 DC	
	LC 79 Diesel SC	LC 79 Petrol SC	LC 79 Diesel DC	LC 79 V6 Petrol DC
Bumper replacement	•	•	•	•
Tow bar – detachable flange				
Wheel locknuts-Set for 5 alloy wheels	•	•	•	•
Rear step tow bar – fixed flange (mild steel)	•	•	•	•
Rubberising	•	•	•	•
Toyota safety film	•	•	•	•
Styling bar	•	•	•	•
Cattle rails			•	•
7" Interactive Display Audio	•	•		

FOR A FULL RANGE OF ACCESSORIES, PLEASE VISIT YOUR CLOSEST DEALER OR VISIT [WWW.TOYOTA.CO.ZA](http://WWW.TOYOTA.CO.ZA)

## Specifications

Land Cruiser 70 specifications	76 Station Wagon Diesel 4.5ℓ V8	79 Single Cab Petrol 4.0ℓ	79 Single Cab Diesel 4.2ℓ	79 Single Cab Diesel 4.5ℓ V8	79 Double Cab Petrol 4.0ℓ	79 Double Cab Diesel 4.2ℓ	79 Double Cab Diesel 4.5ℓ V8
<b>Engine and drivetrain</b>							
Engine	1VD-FTV (EGR)	1GR-FE	1HZ (with EGR)	1VD-FTV (EGR)	1GR-FE	1HZ (with EGR)	1VD-FTV (EGR)
Displacement (cm³)	4461	3956	4164	4461	3956	4164	4461
Cylinder configuration	8 Cylinders, V-type	6-Cylinders, V-type	6-Cylinders, in-line	8 Cylinders, V-type	6-Cylinders, V-type	6-Cylinders, in-line	8 Cylinders, V-type
Maximum power (kW @ r/min)	151 @ 3400	170 @ 5200	94 @ 3800	151 @ 3400	170 @ 5200	94 @ 3800	151 @ 3400
Maximum torque (Nm @ r/min)	430 @ 1200-3200	360 @ 3800	280 @ 2200	430 @ 1200-3200	360 @ 3800	280 @ 2200	430 @ 1200-3200
Valve mechanism	32 Valve, DOHC	24 Valve-DOHC with VVT-i	12 Valve, SOHC	32 Valve, DOHC	24 Valve-DOHC with VVT-i	12 Valve, SOHC	32 Valve, DOHC
Bore x stroke (mm)	86.0 x 96.0	94.0 x 95.0	94.0 x 100.0	86.0 x 96.0	94.0 x 95.0	94.0 x 100.0	86.0 x 96.0
Fuel system	Diesel-common rail	Petrol-EFI	Diesel	Diesel-common rail	Petrol-EFI	Diesel	Diesel-common rail
Compression ratio	16.8 : 1	10.0 : 1	22.4 : 1	16.8 : 1	10.0 : 1	22.4 : 1	16.8 : 1
Transmission	5MT	5MT	5MT	5MT	5MT	5MT	5MT
1 <sup>st</sup> Gear ratio	4.529	4.529	4.313	4.529	4.529	4.313	4.529
2 <sup>nd</sup> Gear ratio	2.464	2.464	2.330	2.464	2.464	2.330	2.464
3 <sup>rd</sup> Gear ratio	1.490	1.436	1.436	1.490	1.490	1.436	1.490
4 <sup>th</sup> Gear ratio	1.000	1.000	1.000	1.000	1.000	1.000	1.000
5 <sup>th</sup> Gear ratio	0.881	0.881	0.838	0.881	0.881	0.838	0.881
Reverse	4.313	4.313	4.220	4.313	4.313	4.220	4.313
Rear differential	3.909 4P Diff lock	4.100 4P Diff lock	4.100 4P Diff lock	3.909 4P Diff lock	4.100 4P Diff lock	4.100 4P Diff lock	3.909 4P Diff lock
Stabiliser	Front only	Front only	Front only	Front only	Front only	Front only	Front only
Front suspension	Rigid axle (coil)	Rigid axle (coil)	Rigid axle (coil)	Rigid axle (coil)	Rigid axle (coil)	Rigid axle (coil)	Rigid axle (coil)
Rear Suspension	Rigid axle (leaf)	Rigid axle (leaf)	Rigid axle (leaf)	Rigid axle (leaf)	Rigid axle (leaf)	Rigid axle (leaf)	Rigid axle (leaf)
Warranty – 3 yrs/100 000 km	•	•	•	•	•	•	•
Service plan (optional) – up to max 7 yrs/200 000 km	•	•	•	•	•	•	•
<b>Wheels and tyres</b>							
Tyre size	265/70R16 Alloy	265/70R16 Alloy	265/70R16 Alloy	265/70R16 Alloy	265/70R16 Alloy	265/70R16 Alloy	265/70R16 Alloy
Spare wheel cover	•	•	•	•	•	•	•
Spare tyre	Full-265/70R16 Alloy	Full-265/70R16 Alloy	Full-265/70R16 Alloy	Full-265/70R16 Alloy	Full-265/70R16 Alloy	Full-265/70R16 Alloy	Full-265/70R16 Alloy
<b>Body and styling</b>							
Over fender (body integrated)	•	•	•	•	•	•	•
Mud guard (front and rear)	•	•	•	•	•	•	•
Side steps	Aluminium	Aluminium	Aluminium	Aluminium	Aluminium	Aluminium	Aluminium
Towing hook (standard -2)	•	•	•	•	•	•	•
Front bumper	Extension (136 mm), painted, chrome	Extension (136 mm), painted, chrome	Extension (136 mm), painted, chrome	Extension (136 mm), painted, chrome	Extension (136 mm), painted, chrome	Extension (136 mm), painted, chrome	Extension (136 mm), painted, chrome
Rear bumper	Plated and bumper corner painted and RR combination lamp						
Front grille	Chrome	Chrome	Chrome	Chrome	Chrome	Chrome	Chrome
Mud guards	Over fender (front and rear) adr	Over fender (front) and std (rear)	Over fender (front) and std (rear)	Over fender (front) and std (rear)	Over fender (front) and std (rear)	Over fender (front) and std (rear)	Over fender (front) and std (rear)
Headlamps	Halogen	Halogen	Halogen	Halogen	Halogen	Halogen	Halogen
Front fog and driving lamp	•	•	•	•	•	•	•
Outside rear-view mirror	Door d and p: convex w/e-mark, plated	Door d and p: convex w/e-mark	Door d and p: convex w/e-mark	Door d and p: convex w/e-mark,plated	Door d and p: convex w/e-mark	Door d and p: convex w/e-mark	Door d and p: convex w/e-mark, plated
<b>Interior, comfort and convenience</b>							
Seat material	Fabric	Vinyl	Vinyl	Fabric	Fabric	Fabric	Fabric
Steering column adjustments	Tilt, telescopic and collapsible	Tilt, telescopic and collapsible	Tilt, telescopic and collapsible	Tilt, telescopic and collapsible	Tilt, telescopic and collapsible	Tilt, telescopic and collapsible	Tilt, telescopic and collapsible
Steering wheel	4-Spoke urethane D390	4-Spoke urethane D390	4-Spoke urethane D390	4-Spoke urethane D390	4-Spoke urethane D390	4-Spoke urethane D390	4-Spoke urethane D390
Shift and lever Knob	Urethane	Urethane	Urethane	Urethane	Urethane	Urethane	Urethane
Power steering (hydraulic)	•	•	•	•	•	•	•
Electrically adjustable windows	With (one touch driver only)	With (one touch driver only)	With (one touch driver only)	With (one touch driver only)	With (one touch driver only)	With (one touch driver only)	With (one touch driver only)
Intermittent rear window washer/wiper	•	•	•	•	•	•	•
Intermittent windscreen wipers	• (time adjustment)	• (time adjustment)	• (time adjustment)	• (time adjustment)	• (time adjustment)	• (time adjustment)	• (time adjustment)

## Specifications

Land Cruiser 70 specifications	76 Station Wagon Diesel 4.5ℓ V8	79 Single Cab Petrol 4.0ℓ	79 Single Cab Diesel 4.2ℓ	79 Single Cab Diesel 4.5ℓ V8	79 Double Cab Petrol 4.0ℓ	79 Double Cab Diesel 4.2ℓ	79 Double Cab Diesel 4.5ℓ V8
<b>Interior, comfort and convenience</b>							
Room lamps	•	•	•	•	•	•	•
Inside rear-view mirror	Day/night	Day/night	Day/night	Day/night	Day/night	Day/night	Day/night
Cup holders	•	•	•	•	•	•	•
Glove box	Lockable	Lockable	Lockable	Lockable	Lockable	Lockable	Lockable
Centre console box	•	•	•	•	•	•	•
Air conditioner (manual)	•	•	•	•	•	•	•
Combination switch	Standard type	Standard type	Standard type	Standard type	Standard type	Standard type	Standard type
Speedometer	Analog	Analog	Analog	Analog	Analog	Analog	Analog
Digital clock	•	•	•	•	•	•	•
Light remind warning( with buzzer)	•	•	•	•	•	•	•
Door ajar warning	•	•	•	•	•	•	•
Audio system with Bluetooth and USB	Toyota/display audio				Toyota/display audio	Toyota/display audio	Toyota/display audio
<b>Safety and security</b>							
Child lock	•						
High mount stop lamp	•						
Driver and front passenger airbags	•	•					
Anti-theft system: siren/alarm and immobiliser	•						
Power door lock	•	•					
Wireless door lock (remote)	•	•					
Rear drum brakes	•	•					
<b>Dimensions and capacities</b>							
Overall length	4910	5095	5095	5245	5095	5095	5235
Overall height	1940	1955	1955	1955	1955	1955	1945
Overall width (mm)	1870	1870	1870	1870	1870	1870	1870
Wheelbase (mm)	2730	3180	3180	3180	3180	3180	3180
Approach angle (degrees)	33	36	36	33	36	36	33
Departure angle (degrees)	23	27	27	27	27	27	27
Front tread (mm)	1555	1555	1555	1555	1555	1555	1555
Rear tread (mm)	1460	1460	1460	1460	1460	1460	1460
Min ground clearance (mm)	230	235	235	235	235	235	235
Front overhang (mm)	860	710	710	860	710	710	850
Rear overhang (mm)	1320	1205	1205	1320	1205	1205	1205
Min Turning Radius (Tyre)	6.3	7.2	7.2	7.2	7.2	7.2	6.3
Interior width (mm)	1515	1510	1510	1510	1515	1515	1515
Interior length (mm)	1700	980	980	980	1660	1660	1660
Interior height (mm)	1215	1120	1120	1120	1225	1225	1225
Gross Vehicle Weight (kg)	3060	3200	3200	3300	3200	3200	3300
Curb Weight (kg) (Max)	2320	2315	2435	2360	2470	2470	2370
Gross Combined Mass (kg)	6560	4700	4700	6800	4700	4700	6800
Max Speed (km/h)	160	165	140	160	165	150	160
CO <sub>2</sub> Emissions - Combined (g/km)	313				343	320	313
Fuel Consumption - Combined (ℓ/100km)	11.9				14.4	12.2	11.9
Towing capacity (kg): Unbraked trailer	750	750	750	750	750	750	750
Towing capacity (kg): Trailer with overrun brake	3500	1500	1500	3500	1500	1500	3500
Load capacity	765	1135	1060	1060	1005	920	960

\* 4.5 litre V8 requires premium Diesel fuel (50 ppm or below) \* Please note that the OBD may result in the OBD indicator light being on depending on the driving conditions. Please take the vehicle to your nearest Toyota dealer if this occurs.



## LC 79 DOUBLE CAB COLOURS

(MODEL SHOWN: LAND CRUISER 79 DOUBLE CAB)



Ivory White (058)



Sand Beige (4E9)

## COLOURS BY SPECIAL ORDER



Satin Silver Metallic (1F7)



Graphite Grey Metallic (1G3)



Ruby Metallic (3Q3)



Golden Beige Metallic (4R3)



Dark Blue (8H6)

## LC 79 SINGLE CAB STANDARD COLOURS

(MODEL SHOWN: LAND CRUISER 79 SINGLE CAB)



Ivory White (058)



Sand Beige (4E9)

## COLOURS BY SPECIAL ORDER



Satin Silver Metallic (1F7)



Graphite Grey Metallic (1G3)



Ruby Metallic (3Q3)



Golden Beige Metallic (4R3)



Dark Blue (8H6)



Toyota vehicles are known for their Quality, Durability and Reliability. Keeping your Toyota Genuine means no compromises in terms of safety, performance and resale value. The range of Genuine Products and Approved Service will ensure complete peace of mind throughout the ownership journey and beyond. For more information on how to keep your Toyota genuine visit [www.toyota.co.za/genuine](http://www.toyota.co.za/genuine)

## TOYOTA GENUINE PRODUCTS

For guaranteed fit and function, Genuine Parts are essential in maintaining the safety and reliability of your vehicle. **Genuine Parts** comply with all safety, regulatory and environmental requirements, making it the obvious choice. The same exacting precision applies to **Toyota Accessories**, developed by engineers with extensive knowledge on vehicle integration - you can enhance the appeal and functionality of your Land Cruiser 70 series without compromising its safety features or warranty. Warranties are about peace of mind, and the **Genuine Unlimited Warranty** is designed to provide superior cover (up to 6 years or 8 years, unlimited mileage) and a seamless claims process thanks to full integration with Toyota systems. The **Genuine Extended Service Plan** also enjoys exclusive approval by Toyota SA and provides flexible extension options up to 7 years or 200 000 km to suit your period of ownership. Paying today's rates for tomorrow's maintenance is a sensible way to protect the resale value of your Land Cruiser 70 series by means of a full service history.

## TOYOTA APPROVED SERVICES

Specialised vehicle maintenance requires first-class facilities, advanced equipment and expert knowledge. **Toyota Quality Service** not only promises accurate diagnosis and repair, but also a philosophy of building trust through a genuine concern for the needs of our customers. To complement the extensive network of Toyota dealers, we have a vast number of **Accredited Body and Paint Repairers**, selected on stringent criteria to ensure outstanding workmanship and customer service. You can maintain your vehicle's pristine condition without compromising its warranty thanks to the exclusive use of Genuine Parts by our Accredited Repairers. Offering 24-hour access to a full complement of assistance and recovery benefits, **Toyota Roadside Assistance** provides the peace of mind that competent support is only a phone call away.

# TOYOTA GENUINE MEANS

✓ UNCOMPROMISED SAFETY ✓ GUARANTEED QUALITY ✓ PEACE OF MIND



Download the **MyTOYOTA** App from the Google Play Store or the Apple iStore to receive the latest Toyota news, keep an eye on your vehicle's finance and book your vehicle for a service. You can also book a test drive or arrange roadside assistance, all on your phone.

## DISCLAIMER:

The information contained in this brochure is provided as is and without any warranties of any kind, whether expressed or implied, including but not limited to, implied warranties of satisfactory quality, fitness for a particular purpose and/or correctness. The contents of this brochure are for general information purposes only and do not constitute advice. Toyota Motor Corporation of Japan and Toyota South Africa Motors (Pty) Limited does not represent or warrant that the information and/or specifications contained in this brochure are accurate, complete or current and specifically stipulates that certain vehicle details and specifications contained in this brochure may differ in available models. Therefore, neither Toyota Motor Corporation of Japan nor Toyota South Africa Motors (Pty) Limited make any warranties or representations regarding the use of the content, details, specifications, or information contained in this brochure in terms of their correctness, accuracy, adequacy, usefulness, timeliness, reliability or otherwise, in each case to the fullest extent permitted by law. Please note that claiming of input VAT needs to be verified by customers prior to vehicle purchase as these rulings are subject to SARS interpretation. Toyota South Africa Motors' rights remain reserved.

## TOYOTA FINANCIAL SERVICES

There is no 'one-size-fits-all' when it comes to vehicle finance and insurance, there is only you. With fast, flexible and convenient services we will structure the perfect Land Cruiser 70 series model deal for you.

At Toyota Financial Services, we believe that purchasing your Toyota should be as enjoyable as driving it. Toyota Financial Services is the fast, flexible and convenient means of financing your Land Cruiser 70 series model. We have created a range of financial products that suit both private and business customers, easily accessible through your local Toyota dealer. We take the hassle out of arranging finance. Toyota Financial Services (South Africa) Ltd is an authorised Financial Services (FSP No. 7454) and Registered Credit Provider (NCRCP62). For comprehensive information about products offered by Toyota Financial Services, visit [www.toyota.co.za/toyota-finance](http://www.toyota.co.za/toyota-finance)



